



## ASSEMBLY INSTRUCTION

SENT MK2 L 5SCNRLHF

ITEM CODE 78882

Imported by Amart Furniture Pty Ltd, Qld, Brisbane Australia.  
For any assistance with assembly or for missing parts please phone  
Amart Furniture, Customer Service Free call 1800 351 084

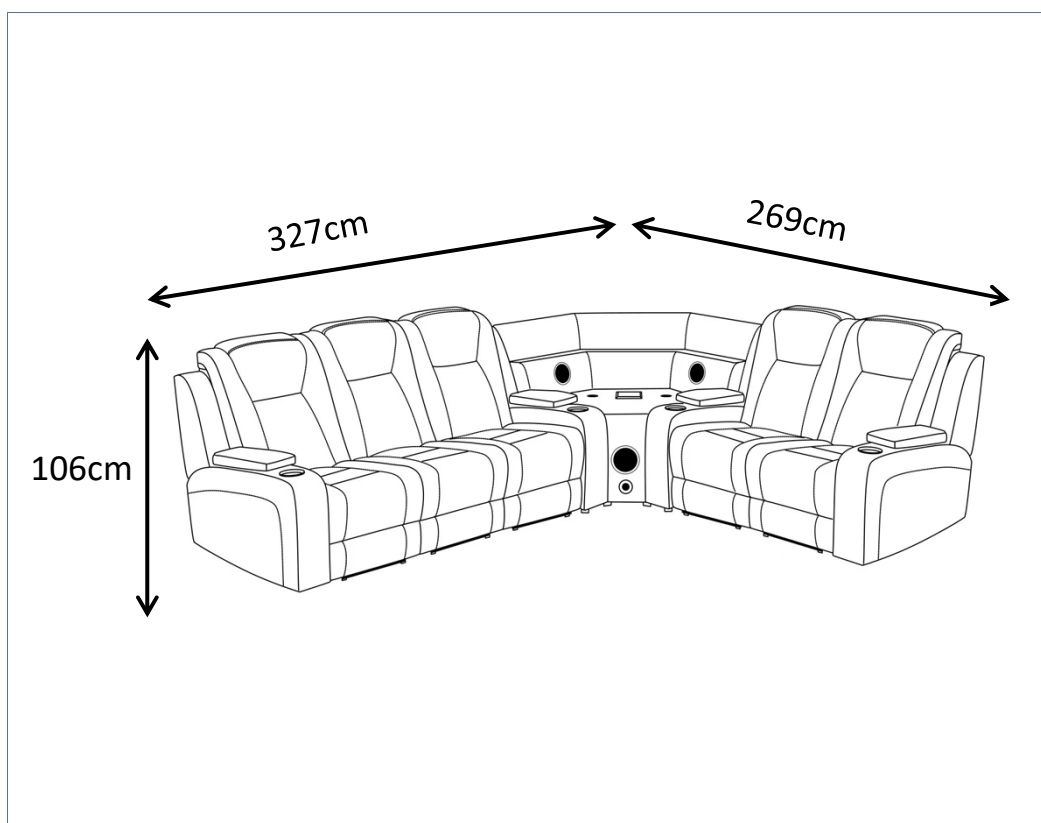



Imported by Amart Furniture Pty Ltd, Qld, Brisbane Australia.  
For any assistance with assembly or for missing parts please phone  
Amart Furniture, Customer Service Free call 1800 351 084

## PRE-ASSEMBLY PREPARATION

### Before you start:

1. Choose a clean, level, spacious assembly area. Avoid hard surfaces that may damage the product
2. Take care when lifting. Product should be assembled as near as possible to the point of use
3. Ensure that you have all required contents for complete assembly
4. Always read the assembly instructions carefully before beginning assembly.
5. Keep all hardware parts and packaging out of reach of small children.
6. Do not over tighten the screws and bolts as this may damage the threads



|  |  |
|--|--|
|  |  |
| ALLOW 40MINUTES  | PEOPLE REQUIRED  |
| ADDITIONAL TOOLS REQUIRED  |  |

### **WARNING**

Do Not allow children to play on this mechanised furniture or operate the mechanism. Leg rest folds down on closing so that a child could possibly be injured. Always leave in an upright and closed position. Keep hands and feet clear of mechanism. Only the occupant should operate it.

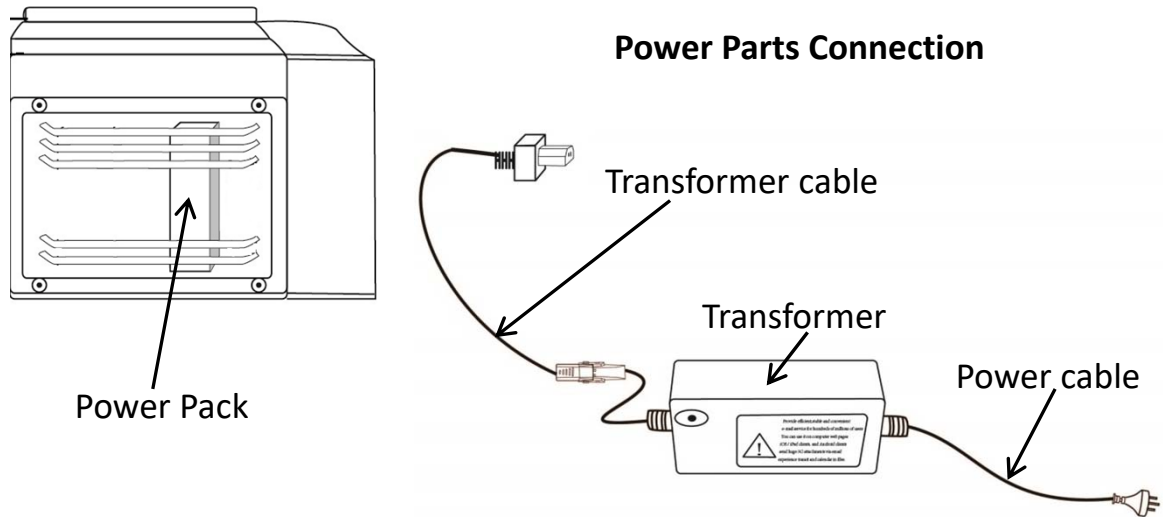
Step1: Locate the left hand facing recliner power pack which is fixed on the mechanism at the bottom of the recliner.

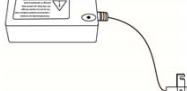

|  |  |   |
|--|--|---|
| <p>Transformer cable</p>  <p>1 pcs</p> | <p>Transformer</p>  <p>1 pcs</p> | <p>Power cable</p>  <p>1 pcs</p> |
|--|--|---|

Step2: Slide receivers into steel mechanism posts at seat of the left hand facing recliner, and press both sides of the back firmly into place to ensure fully locked.

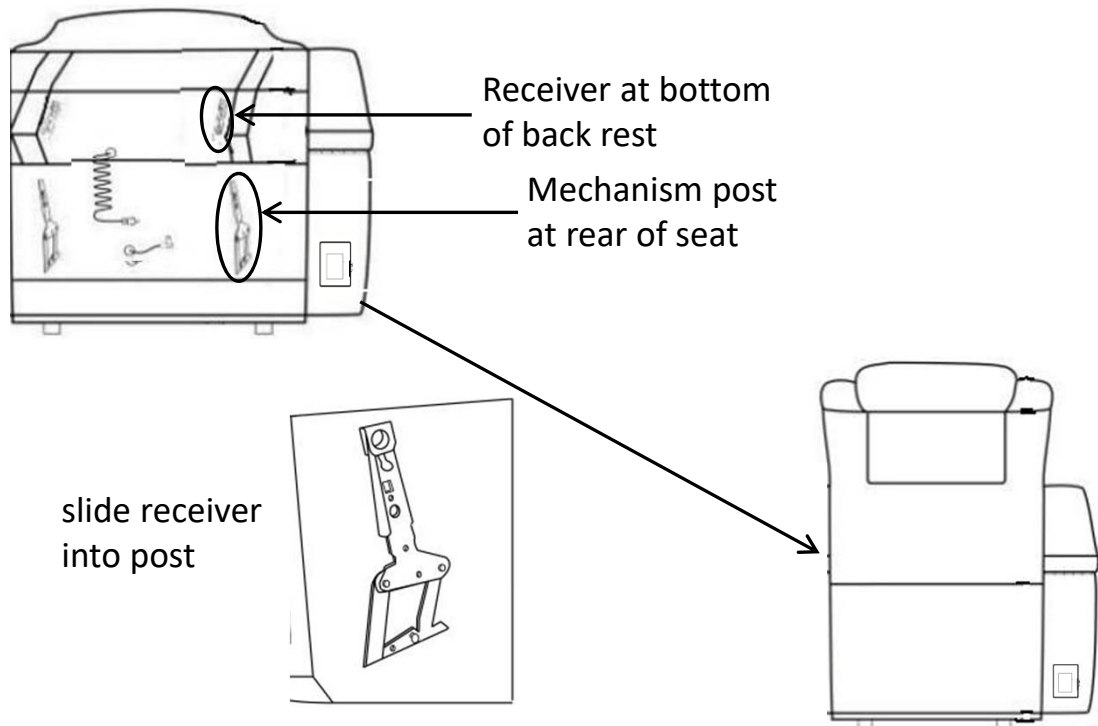

Step3: Connect the cords 'A' and 'B' for power connection between headrest and seat. One cord comes from the back and the other from the seat of left hand facing recliner.

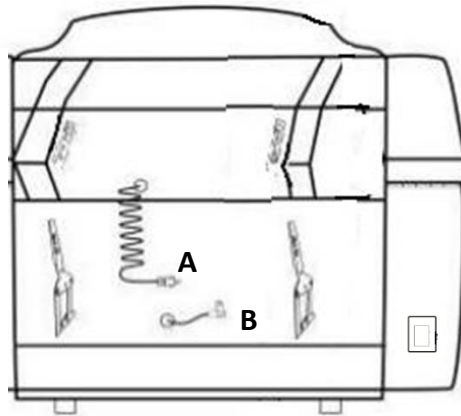

Step4: Slide receivers into steel mechanism posts at seat of the right hand facing chair, and press both sides of the back firmly into place to ensure fully locked.

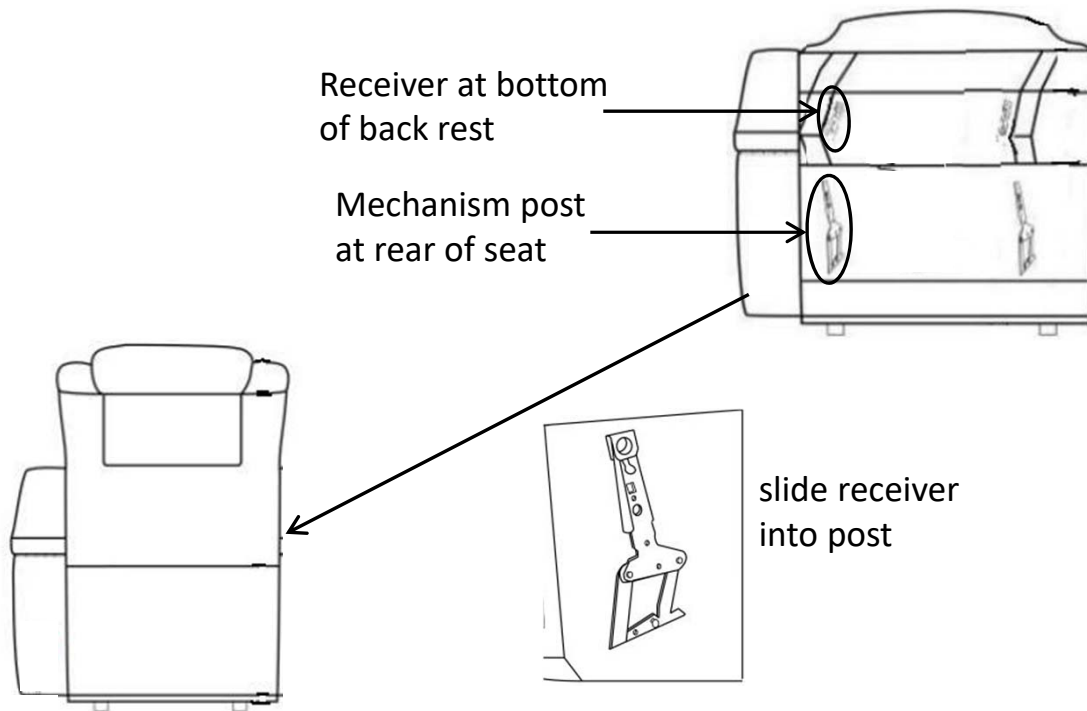

Step5: Locate reading light power cable which is attached to the mechanism post of the armless chair. Keep the power cable to the side. Then unravel the cable 'E' with a plug on the end of it. The cable is from the armless chair back that need be plugged into a wall socket to connect power for charge station on the drop-down console.

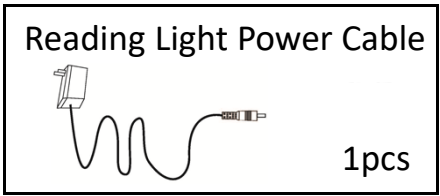
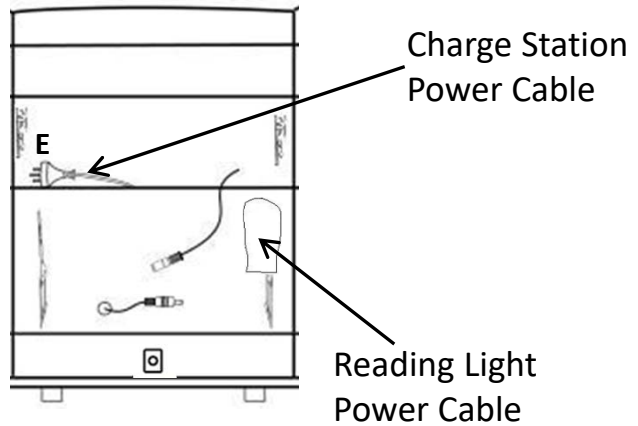

Step6: Slide receivers into steel mechanism posts at seat of the armless chair, and press both sides of the back firmly into place to ensure fully locked.

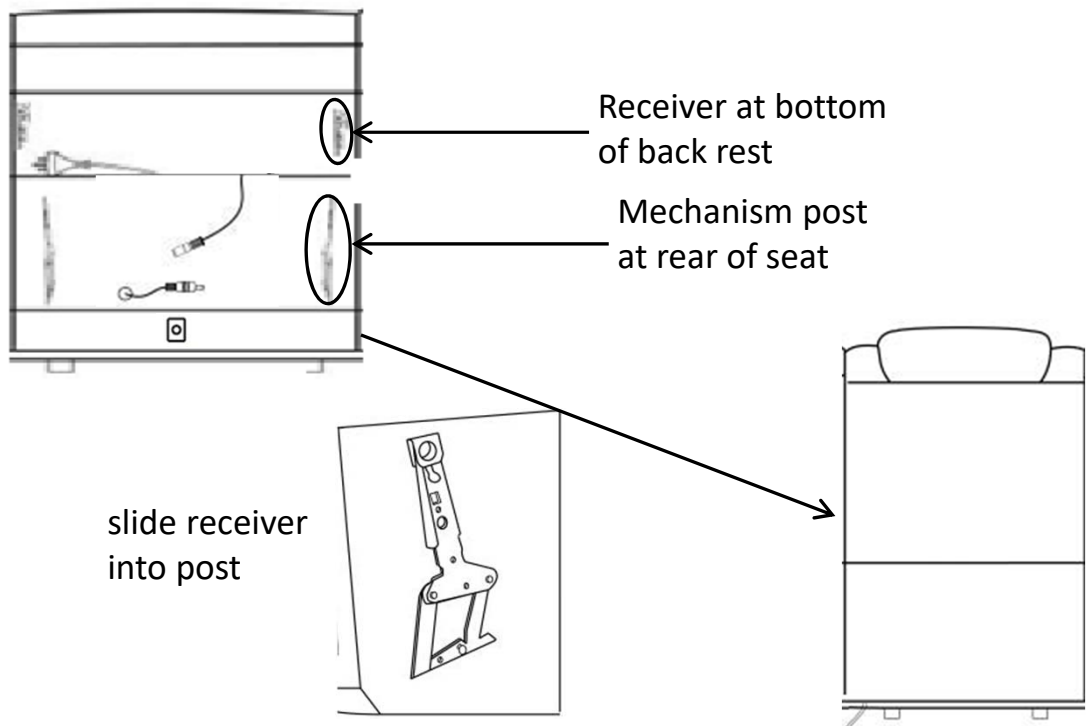

Step7: Connect the cords 'C' and 'D' (below) in the armless chair to connect power for reading lights. One cord comes from the back and the other from the seat.

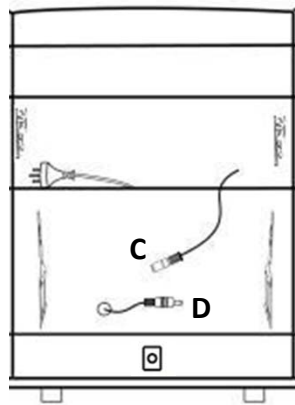



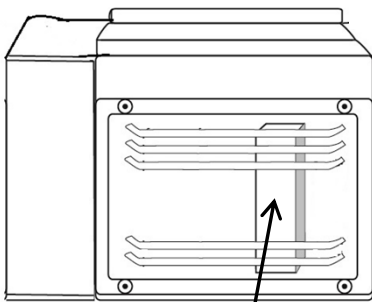

Step8: Locate the right hand facing recliner power pack which is fixed on the mechanism at the bottom of the recliner.

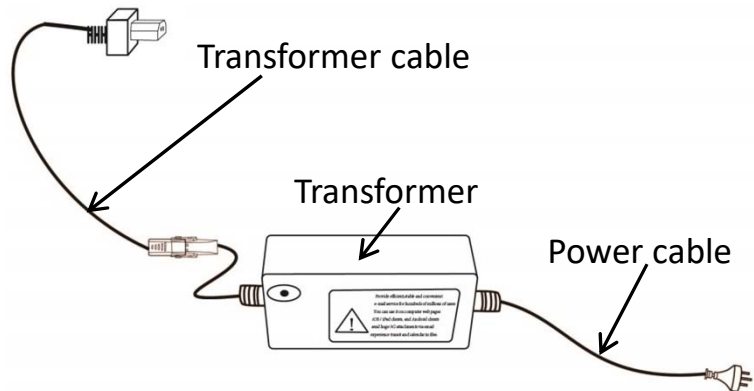

Power Pack

**Power Parts Connection**

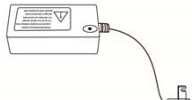

|  |  |   |
|--|--|---|
| <p>Transformer cable</p>  <p>1pcs</p> | <p>Transformer</p>  <p>1pcs</p> | <p>Power cable</p>  <p>1pcs</p> |
|--|--|---|

Step9: Slide receivers into steel mechanism posts at seat of the right hand facing recliner, and press both sides of the back firmly into place to ensure fully locked.

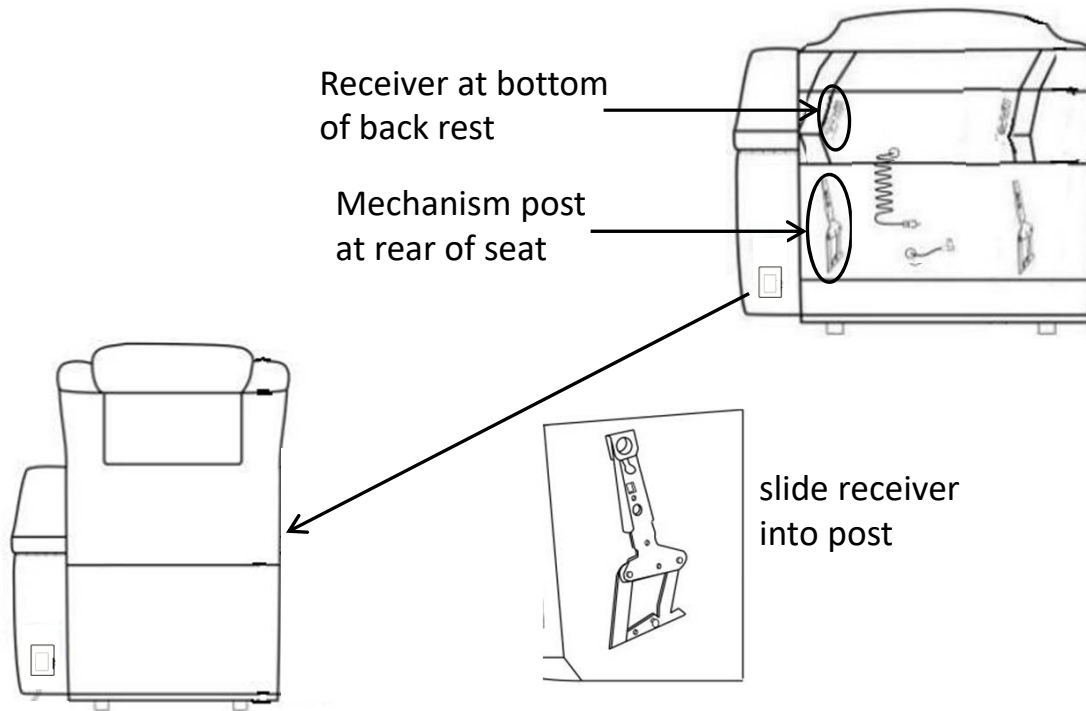

Step10: Connect the cords 'A' and 'B' for power connection between headrest and seat. One cord comes from the back and the other from the seat of right hand facing recliner.

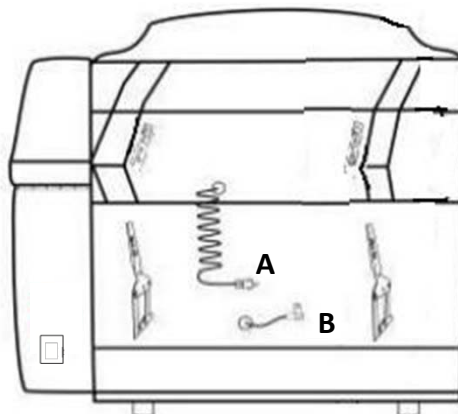

Step11: Slide receivers into steel mechanism posts at seat of the left hand facing chair, and press both sides of the back firmly into place to ensure fully locked.

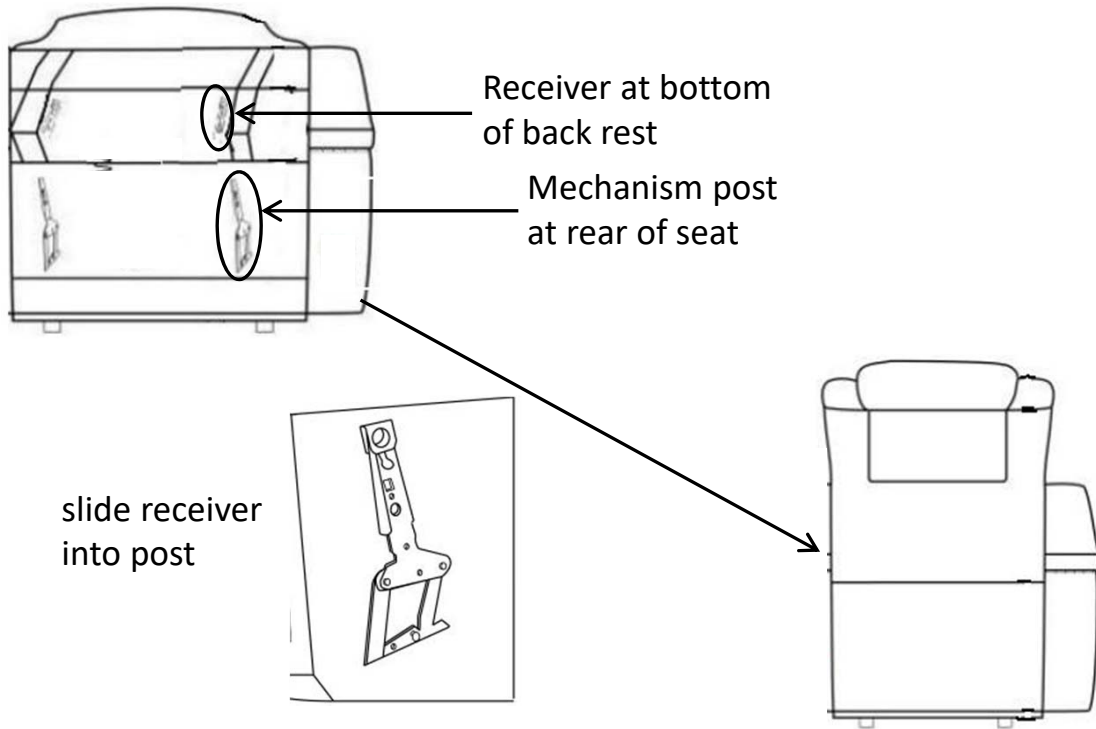

Step12: Locate and remove the Wedge Sofa Feet and Sound Power Pack from the zipper pocket underneath the Wedge base. Keep the power pack to the side.

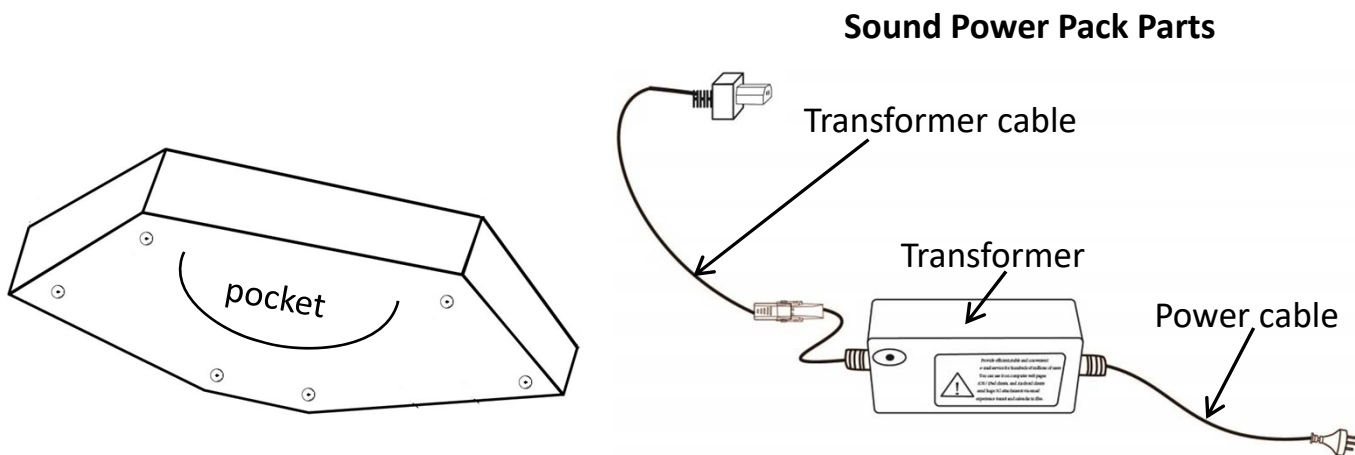

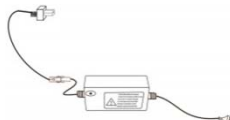

|  |   |
|--|---|
| <b>Plastic Foot</b><br><br>6pcs | <b>Sound Power Pack</b><br><br>1set |
|--|---|

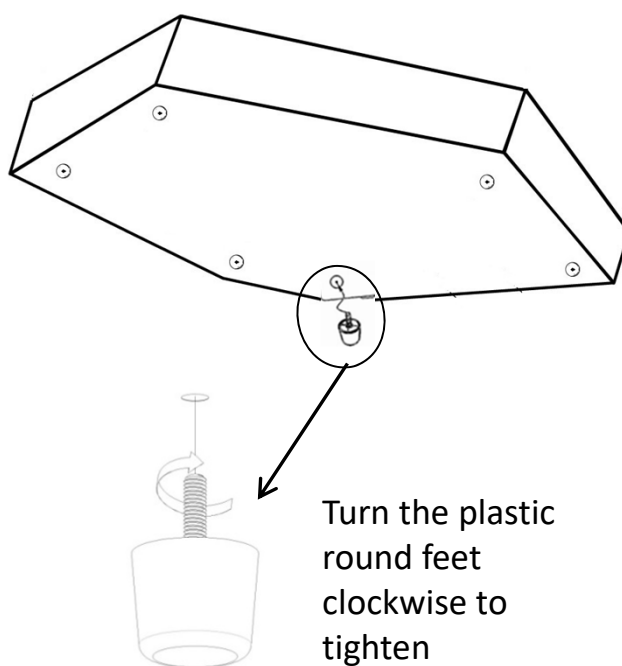
Step13: Secure the 6 x plastic feet provided to the bottom of the wedge base, turning in clockwise direction to tighten.

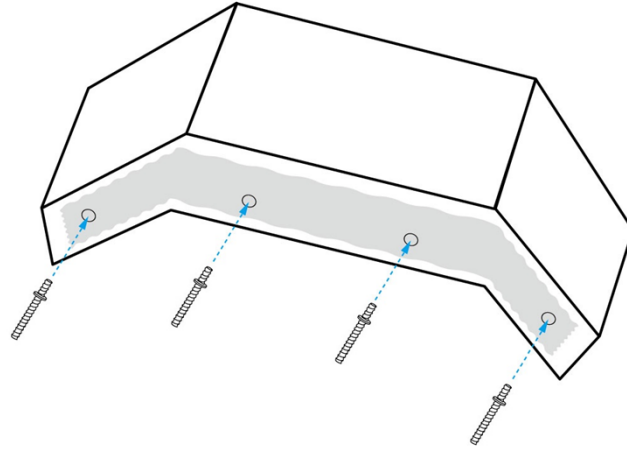

Step14: Remove protective packaging from the wedge back packaged with fittings individually. Then screw the short ends of the bolts into the holes on the bottom of wedge back.

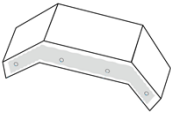
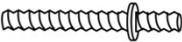

|  |  |   |
|--|--|---|
| Wedge Back<br><br>1pcs | Bolt<br><br>4pcs | Nut<br><br>4pcs |
|--|--|---|

Step15: Poke the wedge back into holes on the rear of wedge base and then fix the back by four nuts screwed inside the wedge base.

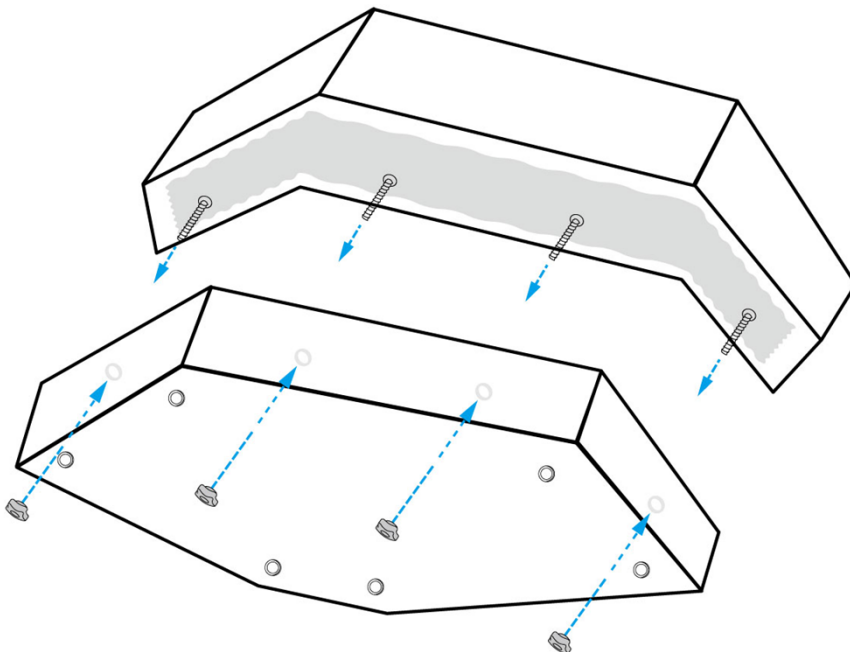

**Step16:** Connect the cords of two speakers being out from the wedge back with cords which are out from the hub box inside the wedge base.

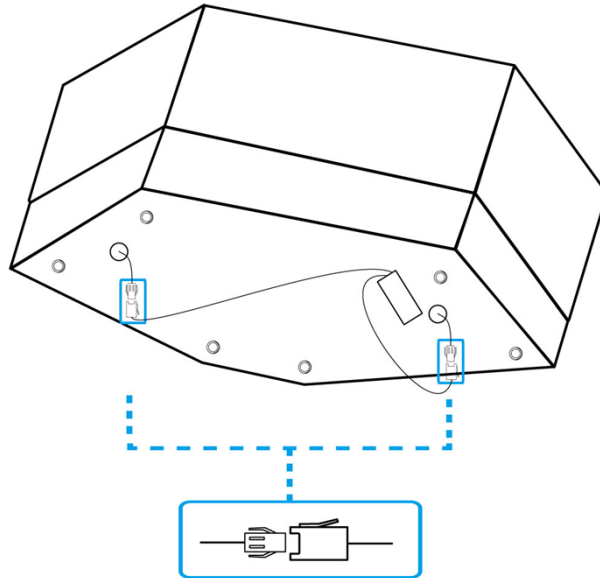

**Step17:** Connect the 3 Seater and 2 Seater respectively from right to left. For 3 Seater, begin with the right hand facing chair, then armless chair, then left hand facing recliner. And for 2 Seater, connect the left hand facing chair to the right hand facing recliner. Slide the base clips together then press the front and rear sides to ensure the clips are connected all the way to the bottom.

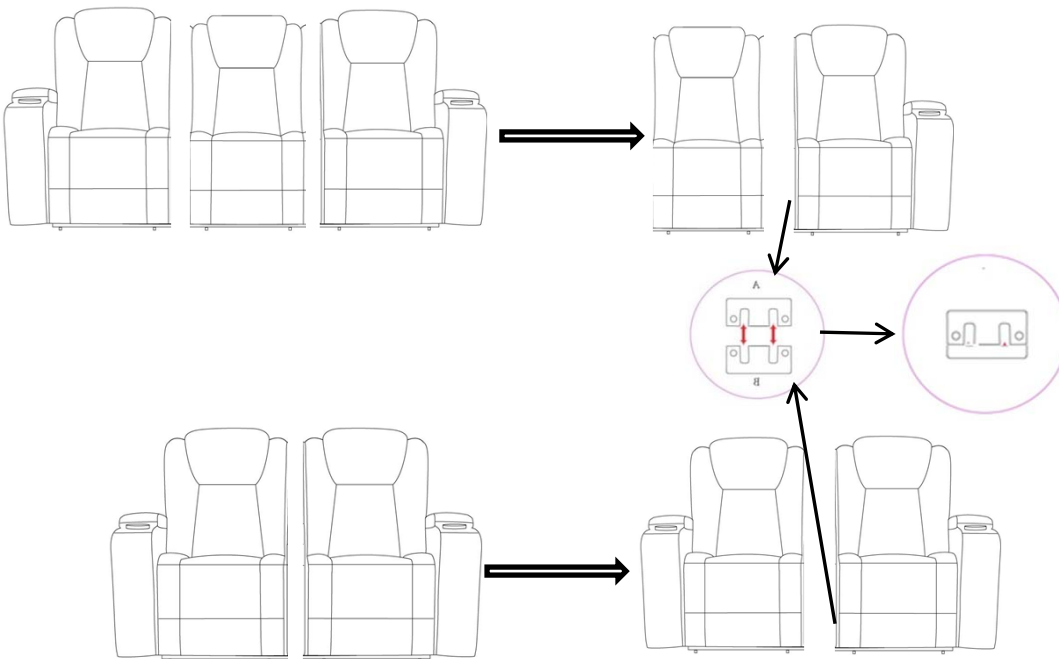

Step18: Unfold connection clips to poke out from bottom of the left hand facing chair and place slidaway parts at bottom of wedge into the clips. Then, unfold connection clips to poke out from bottom of the wedge and place slidaway parts at bottom of right hand facing chair into the clips.

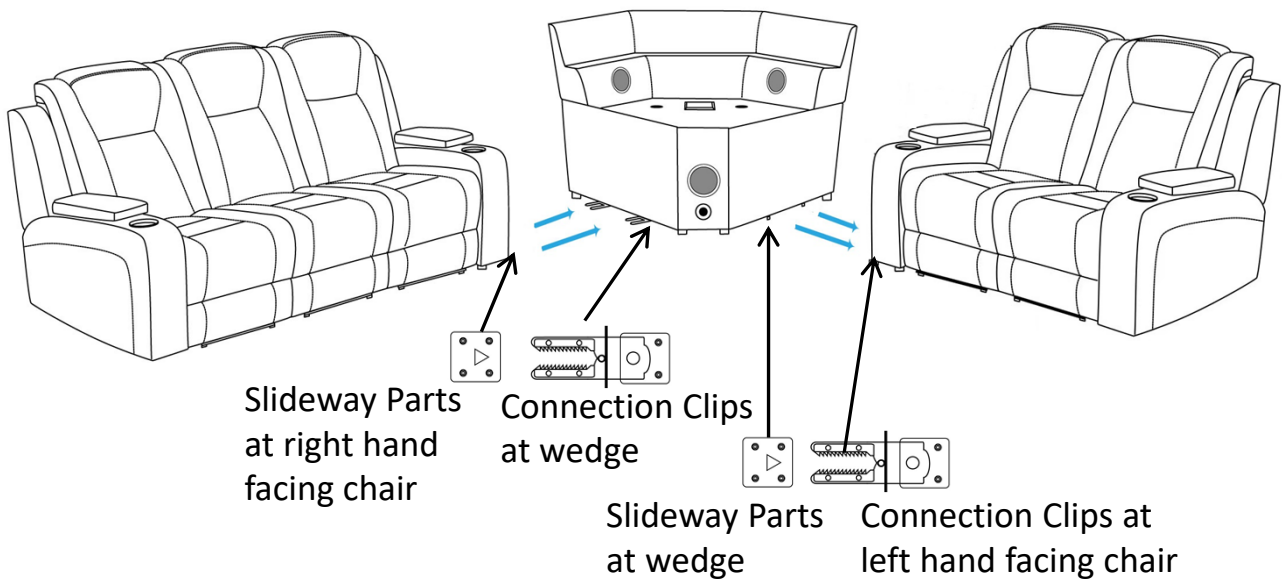

Step19: At the rear and base of lounge, connect the cords for the light strip between each piece of 3 Seater, 2 Seater and Wedge.

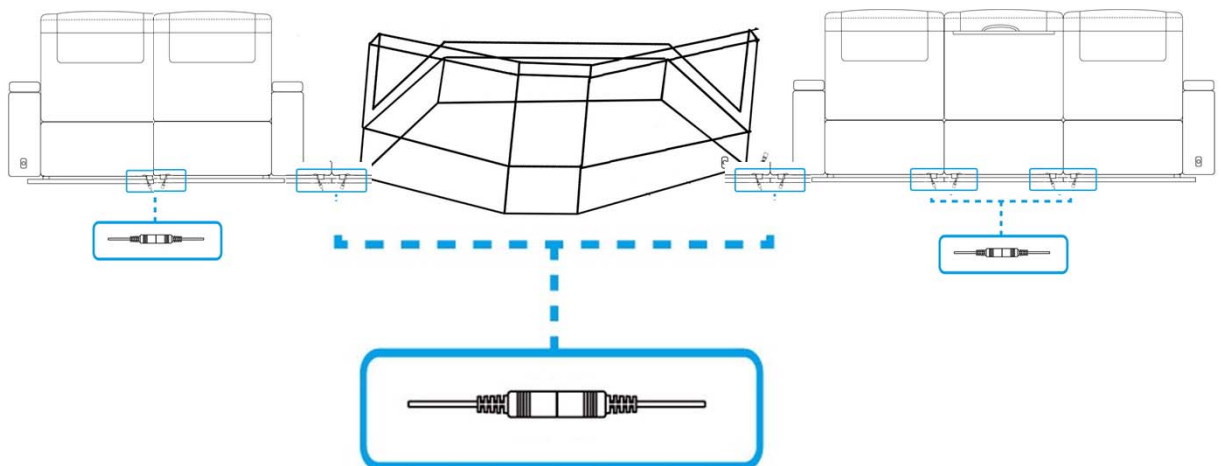

**SAFETY NOTE:**

**PLEASE ENSURE THAT ALL ELECTRICAL CORDS AND CABLES ARE CLEAR OF THE FRAME AND MECHANISM. A FAILURE TO DO SO MAY SEVER YOUR POWER CORD RESULTING IN SERIOUS INJURY OR DEATH.**

Step20: Plug the left hand facing recliner power cable into the back socket of the left hand facing recliner.

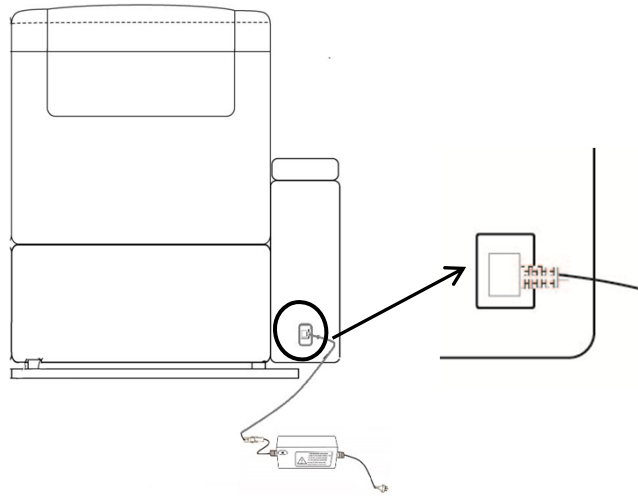

**SAFETY NOTE:**

**PLEASE ENSURE THAT ALL ELECTRICAL CORDS AND CABLES ARE CLEAR OF THE FRAME AND MECHANISM. A FAILURE TO DO SO MAY SEVER YOUR POWER CORD RESULTING IN SERIOUS INJURY OR DEATH.**

Step21: Plug the right hand facing recliner power cable into the back socket of the right hand facing recliner.

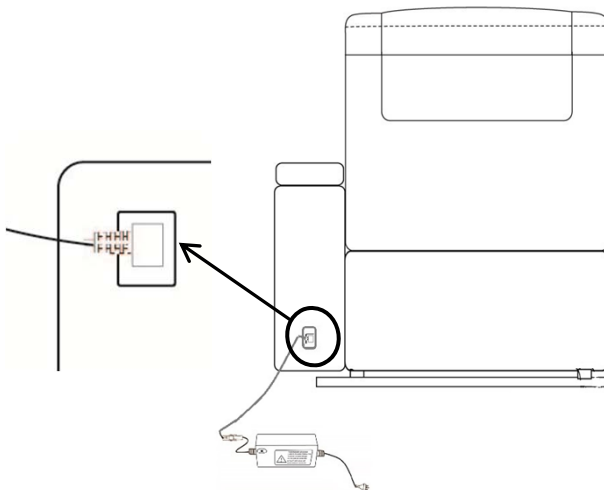

**SAFETY NOTE:**

**PLEASE ENSURE THAT ALL ELECTRICAL CORDS AND CABLES ARE CLEAR OF THE FRAME AND MECHANISM. A FAILURE TO DO SO MAY SEVER YOUR POWER CORD RESULTING IN SERIOUS INJURY OR DEATH.**

Step22: Plug the reading light power cable into the back socket of the armless chair.

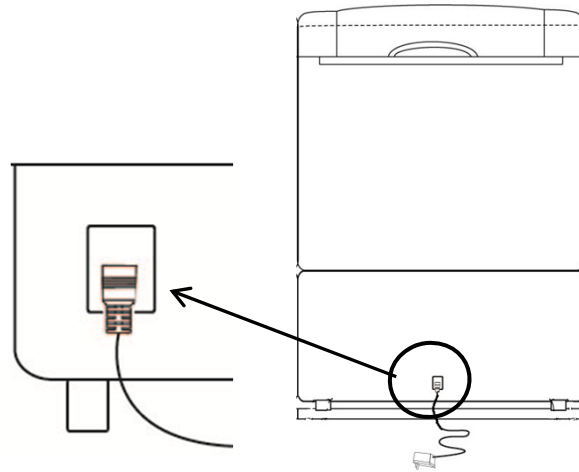

**SAFETY NOTE:**  
**PLEASE ENSURE THAT ALL ELECTRICAL CORDS AND CABLES ARE CLEAR OF THE FRAME AND MECHANISM. A FAILURE TO DO SO MAY SEVER YOUR POWER CORD RESULTING IN SERIOUS INJURY OR DEATH.**

Step23: Plug the sound power pack into the back socket of the wedge.

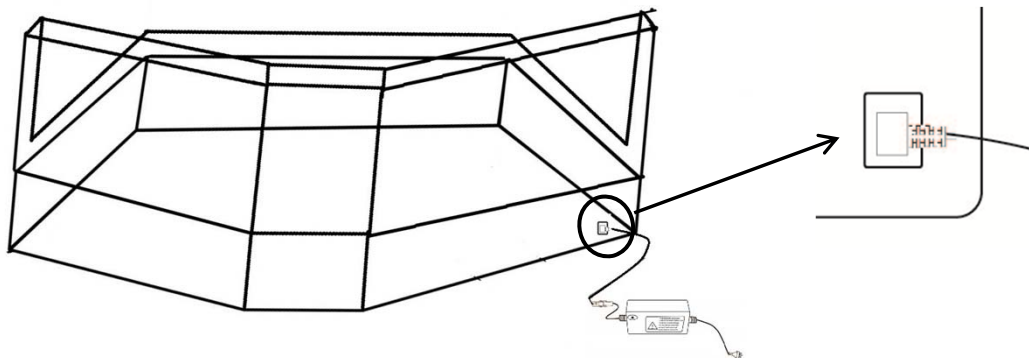

**SAFETY NOTE:**  
**PLEASE ENSURE THAT ALL ELECTRICAL CORDS AND CABLES ARE CLEAR OF THE FRAME AND MECHANISM. A FAILURE TO DO SO MAY SEVER YOUR POWER CORD RESULTING IN SERIOUS INJURY OR DEATH.**

Step24: Plug all power cables into power source / wall. The left recliner power cable, right recliner power cable, reading light power cable, charge station power cable and sound power cable.

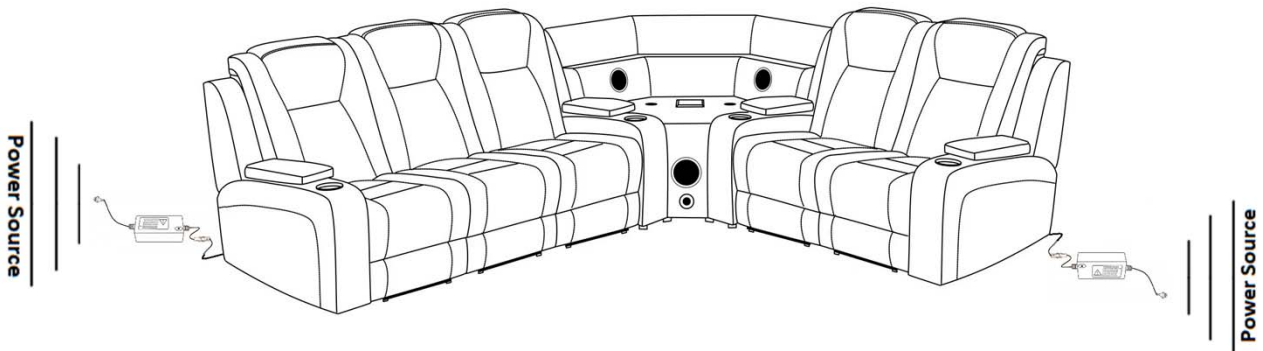

**SAFETY NOTE:**  
**PLEASE ENSURE THAT ALL ELECTRICAL CORDS AND CABLES ARE CLEAR OF THE FRAME AND MECHANISM. A FAILURE TO DO SO MAY SEVER YOUR POWER CORD RESULTING IN SERIOUS INJURY OR DEATH.**

## **READ THESE INSTRUCTIONS THOROUGHLY BEFORE USE:**

### **DANGER:** TO REDUCE THE RISK OF ELECTRIC SHOCK:

Always unplug from electric outlet before cleaning.

### **WARNING:** RISK OF INJURY

Keep children away from extended footrest and any moving parts.

### **CAUTION:**

- Do not allow children to play on this electric recliner or operate the powered mechanism. The leg rest folds when closing and could possibly cause injury to a child. Always leave the recliner in an upright and closed position when not in use. Keep hands and feet clear of mechanism. Only the occupant should operate it.
- Do ensure fully enter the normal sitting position before using of the recliner. Improper sitting, such as sitting in the front of recliner may result in damage to both mechanism and motor drive bar.

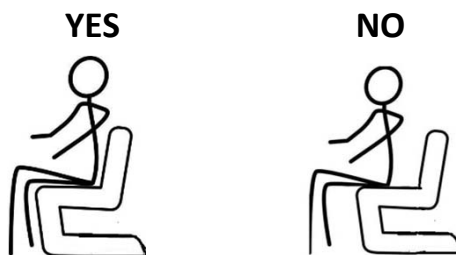

### **POWER CORD SAFETY**

**WARNING:** Unplug and remove power cord from wall when not in use and store out of reach of children.

Take care when moving recliner that wall and transformer cords are not under the base or they may get damaged.

**- NEVER OPERATE ELECTRIC RECLINER IF IT HAS A DAMAGED CORD OR PLUG.**

**WARNING:** TO REDUCE RISK OF BURNS, FIRE, ELECTRIC SHOCK OR PERSONAL INJURY TO PERSONS:

- Use only for its intended purpose
- Never press or activate control switch if you are not seated in recliner
- Only the occupant should activate the control switch
- Never operate with more than one person occupying seat
- Never sit or stand on the footrest

## **CARE AND MAINTENANCE**

### **LEATHER**

WHEN NECESSARY BRUSH OR VACUUM AWAY DUST AND GRIT. WIPE OVER WITH A SOFT, CLEAN, DYEFAST CLOTH.

FOR SPOTS AND SPILLS:  
WIPE EXCESS LIQUID UP IMMEDIATELY WITH AN ABSORBANT CLOTH OR SPONGE.

FOR OVERALL CLEANING:  
WE RECOMMEND CLEANING EVERY 3-4 MONTHS WITH  
· LEATHER CLEANER FOLLOWED BY APPLICATIONS OF  
· LEATHER PROTECTOR.  
ALWAYS FOLLOW DIRECTIONS ON PACKS.

NOTES:  
ACCUMULATION OF PERSPIRATION AND BODY OILS ON ARMPADS, HEADREST ECT. MAY DAMAGE YOUR LEATHER - THESE AREAS MAY REQUIRE MORE FREQUENT CLEANING.

DO NOT EXPOSE LEATHER TO DIRECT SUNLIGHT; INTENSIVE HEAT; WEATHER; OR SOAK UNNECESSARILY. ALWAYS AVOID EXCESSIVE HARD RUBBING.

DO NOT DRY CLEAN OR MACHINE WASH.

DO NOT USE SADDLE SOAP; DETERGENTS; SOLVENTS; ABRASIVES; UNIDENTIFIED LEATHER CLEANERS; SUEDE CLEANERS OR ANY PRODUCTS CONTAINING SILICON OR SOLVENTS.

## Speaker Control Panel Manual

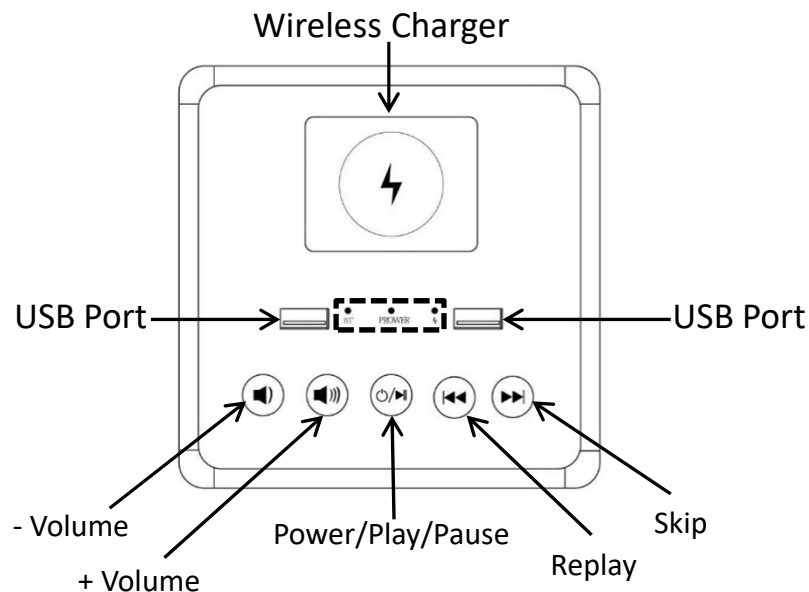

### Speaker Instruction:

#### Bluetooth

- Bluetooth Name: Sentinel MK2
- How to Connect:
  - 1) Hold down the power button for 3 seconds.
  - 2) When the blue light (BT) starts flashing, connect your device. Ensure your device is within range.
  - 3) Once successfully connected the blue light (BT) will stay lit.

#### Speaker Control Panel

- How to use:
  - 1) Hold the power button for 3 seconds to turn on/off.
  - 2) Press the “replay” and “skip” buttons to navigate.
  - 3) Press the “+ volume” and “- volume” buttons to control the sound.

#### Wireless Charge:

- How to use:
  - 1) Place the device in the center of the red wireless charging panel. When the green light is on, wireless charge is successfully in operation.

#### NOTE:

- To indicate that the console is connected to power, the red light (power) will stay lit .
- When the phone is paired and you receive a call or text, the sound will pause.
- The speakers will only work through Bluetooth connection, not USB or Wireless connection.

## Speaker Specifications

- Reproduction system
- Woofer.....  $\phi$ 104mm  
Magnet: 370g
- Tweeter.....  $\phi$ 78mm
- Nominal impedance.....  $6\Omega - 4\Omega - 4\Omega$
- Sensitivity.....  $92 \pm 3\text{dB}$   $82 \pm 3\text{dB}$
- Frequency response.....  $F_0 \sim 10\text{KHZ}$   $F_0-12\text{KHz}$
- Nominal power..... 20W
- Maximum music power..... 32W
- Grille material..... Steel net, ABS
- Weight (per speaker including accessory parts) .....1377g/198g
- Gross weight (2 speakers including packaging) .....1774g

## IMPORTANT INFORMATION

- DO NOT play the speakers for more than 6 hours continuously. In doing so may cause damage to your speakers.

## Wireless Charger Applications

**All cell phones with wireless charging function can be charged.  
The list below shows only some of the phones for your reference.**

| Brand  | Model Number     | Brand                 | Model Number               |
|--------|------------------|-----------------------|----------------------------|
| Apple  | iPhone 13 series | SAMSUNG               | Note 20 series             |
|        | iPhone 12 series |                       | S20 series                 |
|        | iPhone SE2       |                       | S21 series                 |
|        | iPhone 11 series |                       | Galaxy Fold                |
|        | iPhone X series  |                       | SM-G9298                   |
|        | iPhone 8 series  |                       | Galaxy S Lite              |
| HUAWEI | P50 Pro 4G       |                       | Kelly(SM-W2018)            |
|        | P30 Pro          |                       | W2017(SM-W2017)            |
|        | Mate 40 series   |                       | W2016                      |
|        | P40 Pro series   |                       | S10, S9, S8, S7, S6 series |
|        | Mate 30 series   |                       | Note 10 series             |
|        | Mate 20 Pro&RS   |                       | Note 9, Note 8, Note 7     |
| LG     | Optimus series   |                       | Note FE, Note 5            |
|        | Spectrum 2       |                       | Black Berry                |
|        | LG Lucid series  | PRIV                  |                            |
|        | V50 series       | Classic SQC100 series |                            |
|        | V40 ThinQ        | Z30 STA100            |                            |
|        | V35 series       | Q20                   |                            |